

DEVAX

PENETRATING LUBRICANT WITH PTFE

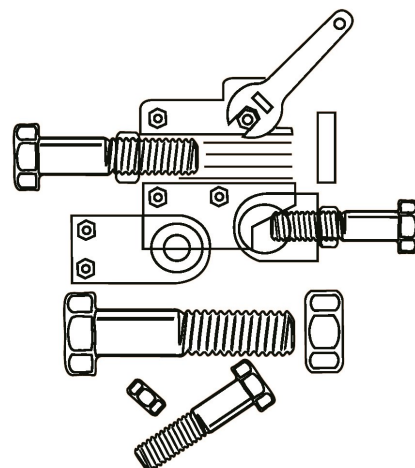

7 good reasons for using DEVAX

1. Fluid lubricant **high level of penetration**.
2. **Ergonomic** spray head with an extender and a classic spraying system.
3. With **PTFE**, offers a powerful lubricant.
4. Decreases the **friction** effectively. High level anti-friction power providing excellent protection.
5. Resists to temperature from **-20 °C to +240 °C**.
6. Provides **DEWATERING** functions.
7. Temporary **protective** effect.

Particularly suitable for use in:



Public buildings



Transport



Construction

Lubricates corroded elements, such as bolts, studs, hinges, axles, rails, sheathed cables, locks, electro-mechanical contacts.

Lubricates mobile parts effectively and durably thanks to the PTFE.

For the cleaning of the slide tracks of tool machines.

Slow drilling of metals.

Characteristics		Instructions for use
Composition oils	oil solvents, special additives, PTFE, anticorrosion.	Shake the spray before using. Spray from a distance of about 20cm on the surface to be treated, let it take effect for a few moments before dismantling. With the 'Cobra' head, for the spraying with the extender, use the aerosol vertically.
Appearance	yellow clear liquid.	
Density	0.8	
Net volume	500 ml	
For more information: see MSDS.		

GB13102022/2

7+

CARLITH: Multi-purpose grease, Lithium-Calcium

This datasheet supersedes previous documents. The information contained in these data sheets is based on our present knowledge and experience and is given as indication only. Under no circumstances does it engage our responsibility in the event of misuse of our products. Non-contractual photos and images.



Tél 02 97 54 50 00
Www.7darmor.fr

